

Press-N-Lok™ Pin

SPIROL is pleased to announce the expansion of their Solid Pin Product Line to include the new Series BP100 Press-N-Lok™ Pin. The new Press-N-Lok™ Pin was designed to permanently retain two plastic components to each other. The pin has opposing raised barbs on each end that are angled backwards opposite to the direction of insertion. As the pin is being inserted, the plastic backfills into the area around the barbs resulting in maximum resistance to axial force providing a secure, tamper resistant assembly. The Press-N-Lok™ Pin is manufactured from lightweight, lead free, corrosion resistant aluminum. One major advantage of the Press-N-Lok™ Pin is that assembly time is quicker and it requires lower assembly equipment costs as compared to screws and adhesives.

Washer Sorting Machine

OSI (Japan) is a manufacturer specialized in visual inspection machines whose products have been adopted by National Machinery from the U.S. OSI successfully developed a flat washer sorting machine called "Ultra View-SLD". The code SLD represents "slide" which means by rolling the flat washers, the machine can check the front and back sides via its camera. The first generation of the machine can check flat washers in outer diameters from 10 mm to 30 mm. Supply has been launched since October 2020.



Stainless Steel Adjusting Screws

for Perfect Positioning

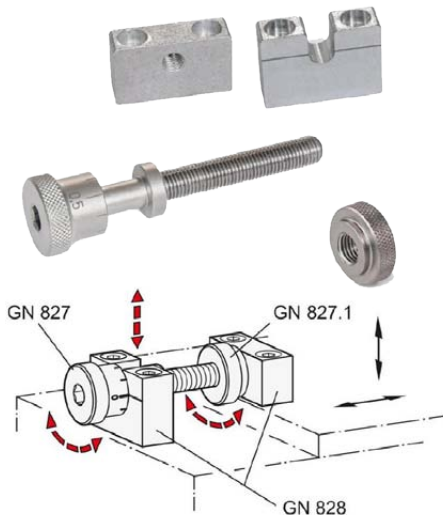

On production machines and mechanisms, it is often necessary to carry out repeated positioning operations as simply and reliably as possible. For precisely such secure and simple adjustments as well as for quick changing of mechanisms or tools, Winco now offers three new parts that complement each other perfectly: stainless steel adjusting screws with an adjustment scale plus matching bearing blocks and knurled nuts. The innovative stainless steel adjusting screw GN 827 from Winco, the specialist of standard parts, is intended for use with bearing blocks GN 828 and simplifies the attachment of parts to various processing and assembly mechanisms in machines, installations and jigs. This means that processes that require the repositioning and adjustment of devices can be carried out much more quickly. The mechanisms are moved into or out of position using an adjusting screw with rotating knob and hexagon socket fitted with a scale with 0.1 mm graduations.



New Clinching Stud Bolts

Clinching stud bolts are commonly used in the automotive industry. Pressing clinching stud bolts into materials often causes materials to warp or develop burrs which impacts the precision and quality of products. Japan Nitto Seiko's new clinching stud bolts can reduce warping and burrs and further decrease spinning. The inside of the lobe-shaped protruding part has a concave to house the deformed material. The deformed portion will stick out towards the male threads to prevent burrs as well as spinning. The product is pending for patent. The company is set to produce 1 million pieces per month.

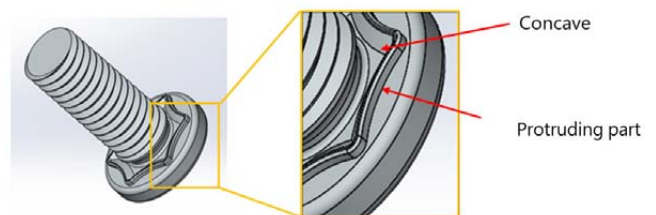

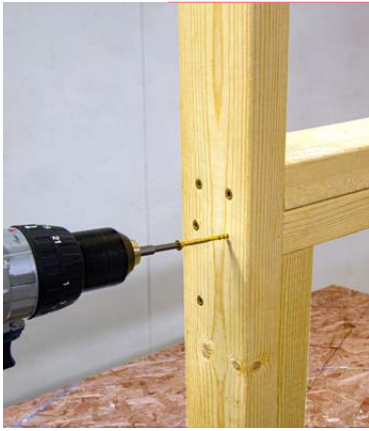

Multipurpose Strong-Drive® CSV Construction Screw

Simpson Strong-Tie, the leader in engineered structural connectors and building solutions, announced the expanded availability of its popular Strong-Drive CSV Construction screw to hardware and fastener suppliers in US markets. Available in 2½" and 3" lengths and coated with yellow zinc for protection against corrosion, the CSV Construction screw is a versatile, multipurpose fastening solution for a variety of wood-to-wood and engineered wood interior applications. Featuring under-head nibs, low-torque threads and a fast-start point, the CSV Construction screw drives effortlessly and is designed for general-purpose fastening. Additional features of the CSV Construction screw include the following: (1) Low-torque threads allow up to 35% more drives per battery charge. (2) Ribbed-head design countersinks easily and provides a clean, finished appearance. (3) High-low point provides fast starts. (4) Optimized threads are ideal for dimensional lumber. (5) T25 6-lobe driver bit included.

Self-undercutting Anchor

Japan Sunco Techno's self-undercutting anchor creates and expands an undercut hole in the wall in the fastening process while skipping many steps. The anchor body as well as its dedicated fastening tool contains a color mark for visual check to confirm the installation. The anchor's tensile strength is 400N/mm² and the yield strength is 240N/mm². It has a mortise-like design through which a dedicated removal tool working as a tenon can extract it from the wall. The anchor is currently used on metal stairs, tunnel light hangers, overpasses, and in machine installation. It is available in steel and stainless steel.

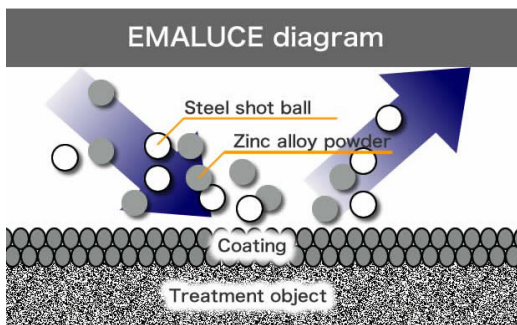

EMALUCE Dry Plating Technology

Plating processes often involve using a liquid agent, and therefore, they are mostly termed "wet plating". The EMALUCE plating by the Japanese Emanak Group differs greatly from other plating processes in that it uses dry plating without a liquid agent. EMALUCE eliminates the risk of stress reduction caused by heat and hydrogen embrittlement, and provides a high-level anti-corrosion effect on products such as high-strength bolts that are difficult to be plated. Benefits: 1. Capable of treating both ferrous and nonferrous materials; 2. No stress reduction thanks to dry plating at room temperature; 3. Less acid treatment and electrolytic reactions; no hydrogen embrittlement; 4. No sealing required; 5. Mechanical properties improved from the peening effect; 6. Environment-friendly.

Prehold Washer

"Prehold Washer" by Taiyo Stainless Spring (Japan) is used for temporary fixing and improves operating efficiency. It is made of stainless steel, corrosion resistant and high strength. It allows a bolt to be inserted through its either sides and provides ease of bolt installation onto the automotive or machine components. The bolt and the components are fastened through spring reaction force.

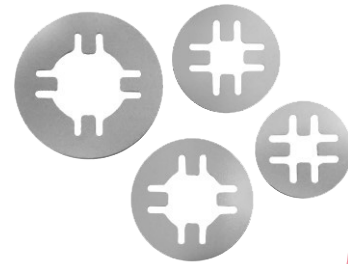

New Rust Prevention Line for High-salinity Environment



Zinc depletion is often faster than expected when using zinc-rich paint in a high-salinity environment. On the other hand, the silicon-based ZECCOAT coating tends to gradually lose effect as the zinc-based anti-corrosion layer wears off. Therefore, Roval and Hoden Seimitsu have joined forces to develop a rust prevention line which will incorporate the following features: 1. Suitable for iron and galvanized surfaces. Able to keep automated parking garages, iron stairs, pipelines and bridges from corrosion; 2. Heavy metal free, eco-friendly and highly corrosion resistant; 3. Reducing zinc depletion in high-salinity environments, inhibiting corrosion and lowering maintenance cost.

